

**WESTERN-CULLEN-HAYES, INC.**

120 N. 3rd. Street • Richmond, Indiana 47374

(765) 962-0526 • Fax (765) 966-5374

Web Site: www.wch.com E-mail: wch@wch.com



Installation Instructions for Western-Cullen-Hayes Sliding Derails

- 1.) **Site Selection:** When selecting a location for the installation of a Hayes Derail several factors should be taken into consideration. Derails should never be installed in paved areas or on the bottom or inside rail of a curve. Special attention should be given to the surrounding area as well. Rolling equipment should not be derailed towards buildings, fences or other structures. Derails should be placed far enough ahead of any area being protected to ensure that the derailed equipment is safely stopped. The derail site should be well drained to prevent the accumulation of water around the equipment.

Fig. 1-1) Correct Location of Derail on a Curve

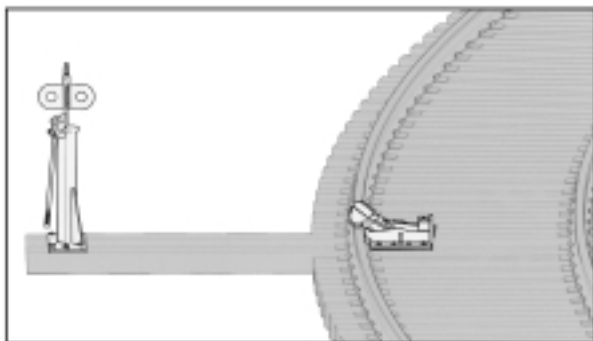
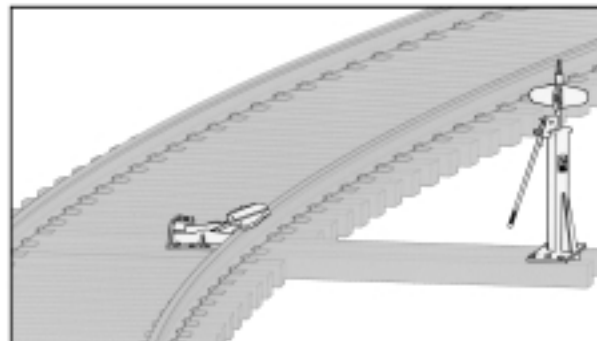

Fig. 1-2) **Incorrect** Location of Derail on a Curve



- 2.) **Derail Size:** Western-Cullen-Hayes Derails are manufactured in five sizes (4 through 8 except Model HBXS which are 6,7,8) to ensure proper fit to a variety of rail sections. Each size derail corresponds to the height in inches from the top of the mounting surface, including tie plate, if used, to the top of the rail. For example a size 7 derail fits a 7 inch application. Our derails can accommodate rail height of not more than 1/2 inch greater or less than their size number by means of shimming the derail up or adzing the tie surface down. It is very important that derails fit the rail properly in order for them to function as designed.

Fig. 2)

Derail Size	Distance from Top of Rail to Tie Surface (Inches)
4	3-1/2" to 4-1/2"
5	4-1/2" to 5-1/2"
6	5-1/2" to 6-1/2"
7	6-1/2" to 7-1/2"
8	7-1/2" to 8-1/2"

- 3.) **Derail Direction:** Derails come in left hand, right hand or bi-directional "XS" models. To determine the required hand of a derail, stand between the rails looking in the direction of the area to be protected. Then decide if the rolling equipment should be derailed to the left or right. Keep in mind that a right hand derail is mounted on the right side of the track and will derail to the right and conversely for a left.

Fig. 3-1) Site Selection - Derailing Intruding Equipment.

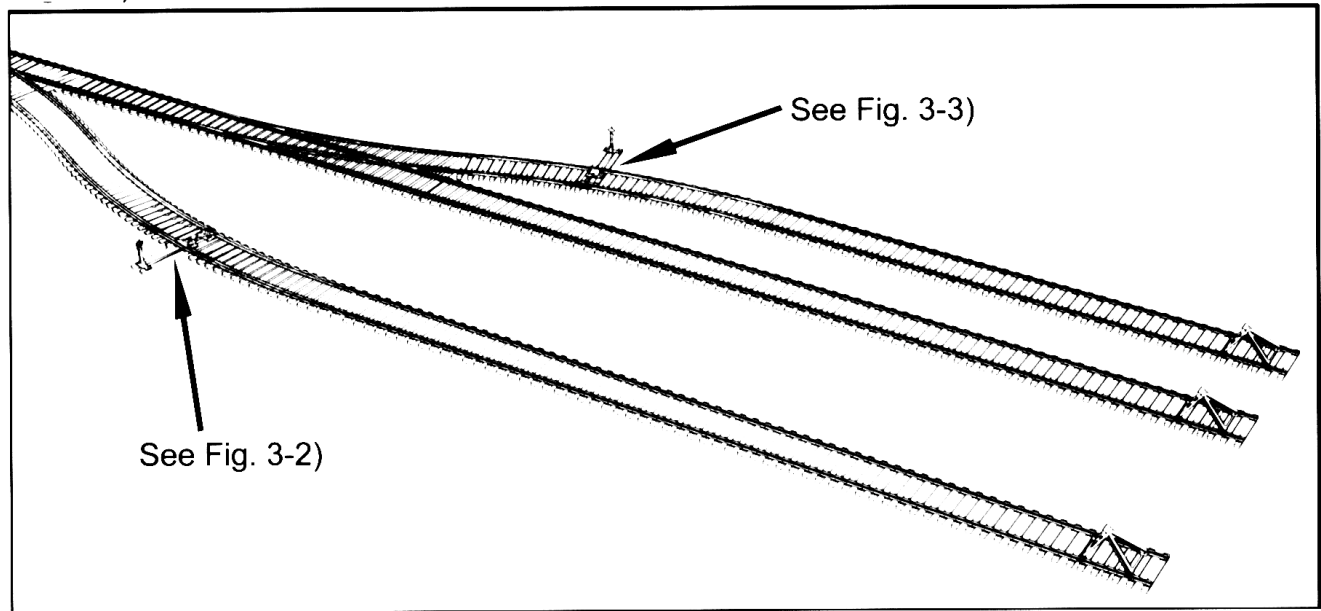
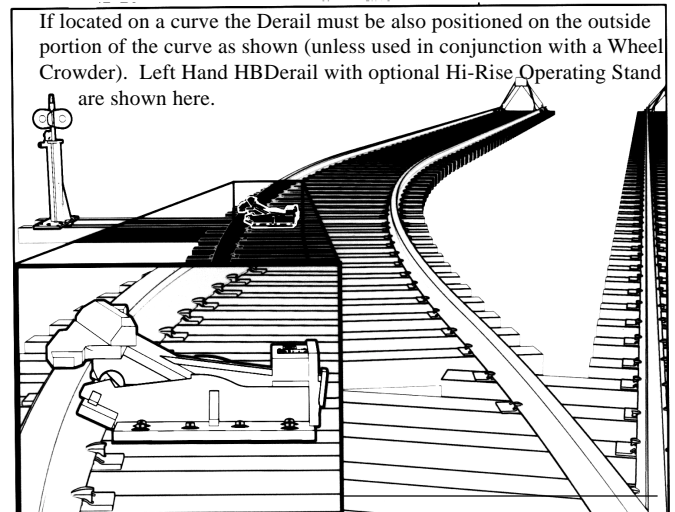
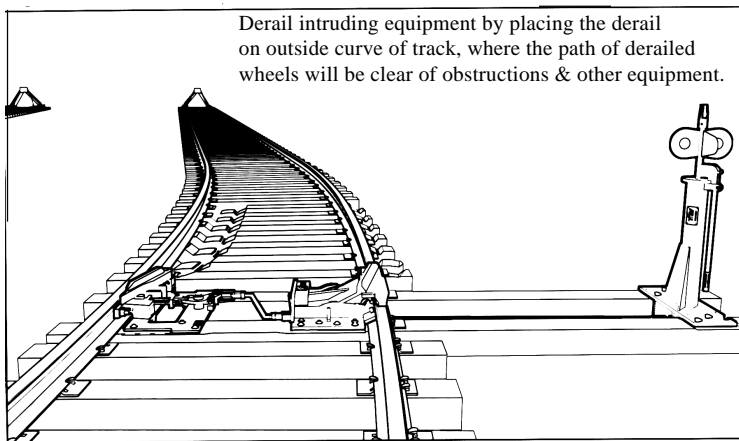

Fig. 3-3) Derailing Intruding Equipment to the left

Fig. 3-2) HB Right Hand Derail with Crowder and Hi-Rise Operating Stand



This is important when placing the Operating Stand as well. Ample clearance must be provided between adjacent tracks and other possible equipment or structures. Care should be taken to avoid derailing toward buildings, ditches, paved areas or other tracks where derailed equipment could obstruct movement on that track. Bi-directional "XS" derails should only be used when it is absolutely necessary to derail equipment entering and exiting a specific area, such as a locomotive shop.

4.) Installation: Once the location, size and direction of the derail have been determined the final installation takes just a few minutes. The two cross-ties under the derail should be new, grade 5 ties at least 14 feet long. The ties should be parallel and level and well ballasted.

Fig. 4-1) Plan View of Installed Derail.

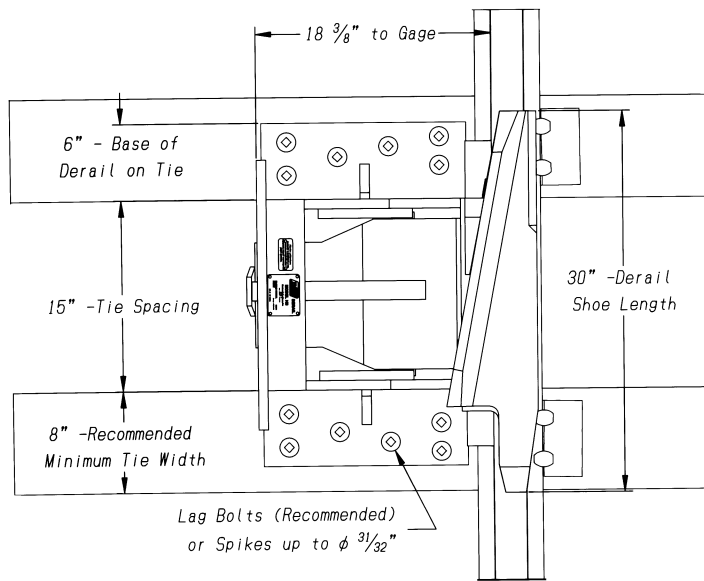
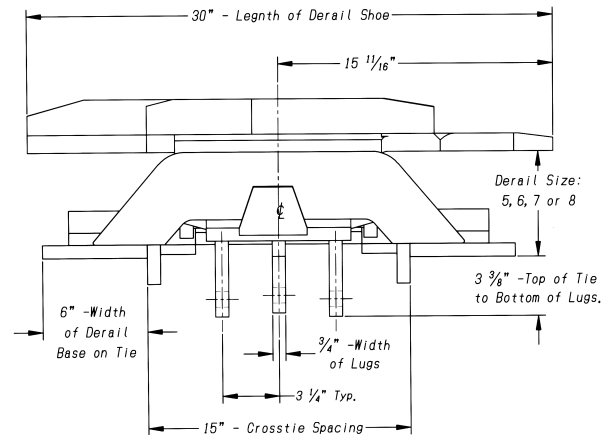
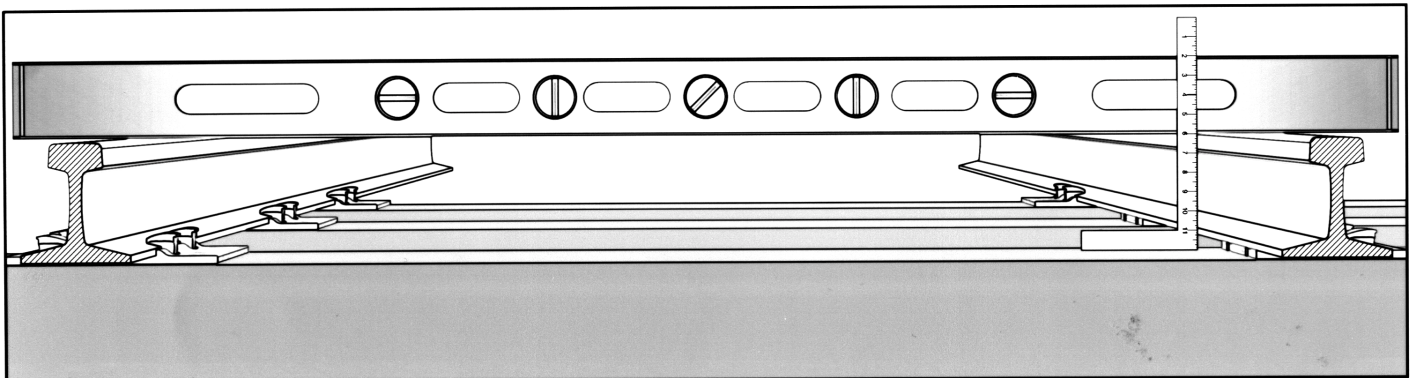

Fig. 4-2) Rear View of Derail showing connecting lugs and dimensions.



If tie plates are used, they must be cropped even with the base of the rail on the gauge side of the rail. Particular attention must be paid to the height of the rail and tie plates, either shim the derail or adz the ties as required. Remember, the total height of the derail must equal the total height of the rail and tie plate combination. For example, a rail and tie plate 7-1/2 inches high should have a number 7 derail with a 1/2 inch shim under it so they equal 7-1/2 inches as well.

Fig. 5) Measure from the top of ties to the top of rail, cropping tie plates first (as shown).



Place the derail between the rails and shove the front of the guide box to within 1/2 inch of the web of the rail. Remove the two wire ties that secure the derail block to the box for shipping purposes. Next, slide the derail block up and onto the railhead as far as it will go. It should overhang the rail head by a minimum 1/2 inch to the field side. Now, push the derail box toward the web of the rail until just before the derail block starts to lift up. At this point, the thrust shafts and seats have made contact. When properly installed there should be no gap between the top of the rail and the underside of the derail block and no gap between the thrust shafts and the seats in the derail guide box. Make sure the vertical flanges of the guide box are flush against the crossties. The derail block should be level on the top of the rail and the vertical stops under the derail block will be against the gauge of the rail head. Next lag bolt the derail to the crossties using all the available holes in the horizontal flanges. These holes are 31/32 inch in diameter and will accommodate bolts up to 15/16 inch. When in the derailing position, the derail block should cover the head of the rail completely and over hang the rail 1/2 inch minimum, to the field side.

Fig. 6)  
Size 6 Derail on a 6" application.

Fig. 7)  
Size 6 Derail on a 6-1/2" application.

Fig. 8)  
Size 6 Derail on a 5-1/2" application.

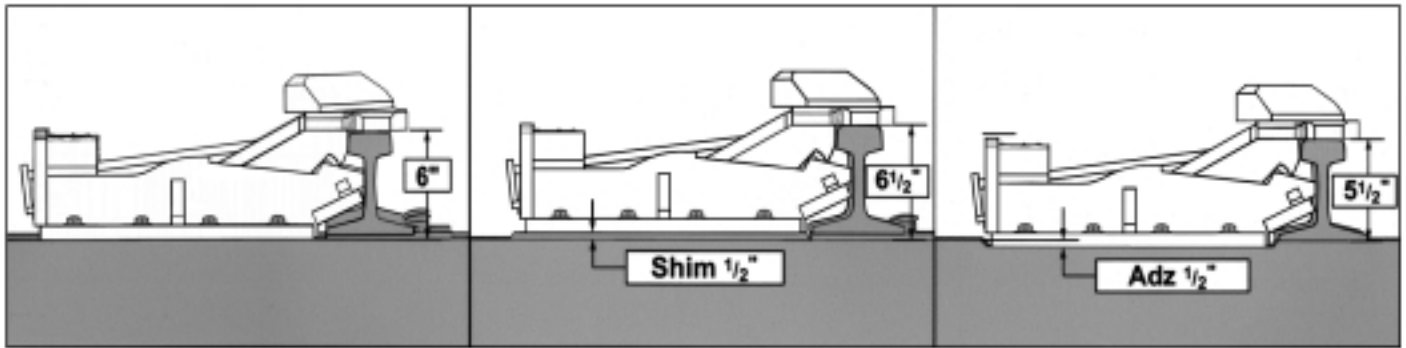

5.) **Operating Stands:** Western-Cullen-Hayes manufactures four types of manual operating stands for our sliding derails, a high rise stand, standard two tie stand, a one tie stand and low profile two tie stand. The standard connecting rod for the high-rise stand is 8'-2" long. The one and two tie stand rod is 5'-2", the rod for the close coupled stand is 3'-1", other rod lengths are available. If using a manual switch stand or power switch machine to operate a Hayes Sliding Derail, a Short Stroke Derail must be specified.

Fig. 9) HB R.H. Derail with  
Two Tie Operating Stand,  
Near rail application.

Fig. 10) HB R.H. Derail with  
Hi-Rise Operating Stand,  
Far rail application,

Fig. 11 ) HB R.H. Derail with  
Hi-Rise Operating Stand,  
Near rail application.

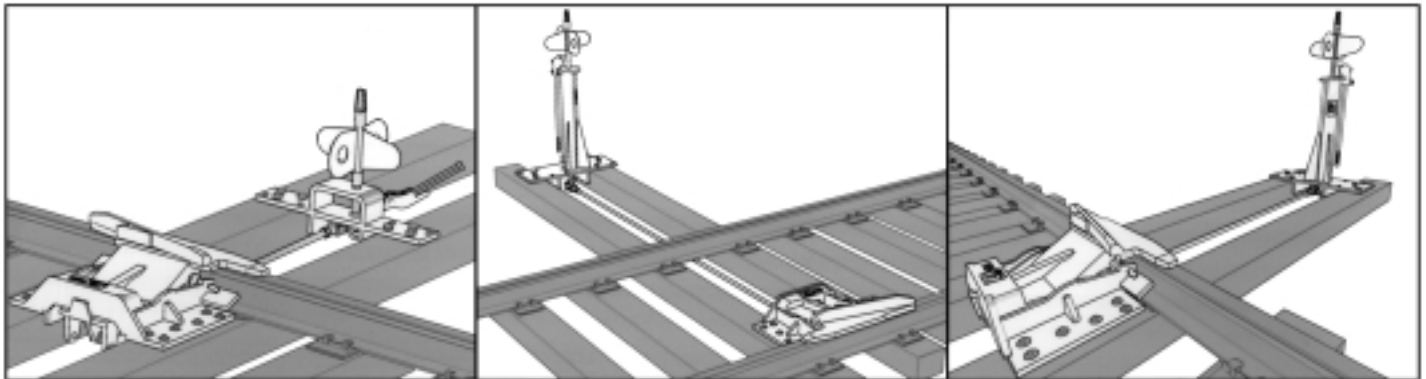

6.) Place the operating stand on the field side of the track closest to the derail. With the derail in the "on rail" position and the operating stand in the "on rail" position the eye bolt angled away from the derail. Attach the connecting rod screw jaw to the center lug of the derail and to the eye bolt of the operating stand. The connecting rod should be parallel to the ties. The connecting rods have screw jaws on both ends to permit minor adjustment of the rod length. The stroke of the operating stand is adjusted by means of the eyebolt to which the connecting rod is attached. The working stroke of a standard derail is 6-1/4 inches. There is a special 5-1/4 inch short stroke derail identified by a "SS" on its nameplate. Make sure the connecting rod is parallel to the ties. Secure the operating stand to the cross ties using just two lag bolts.

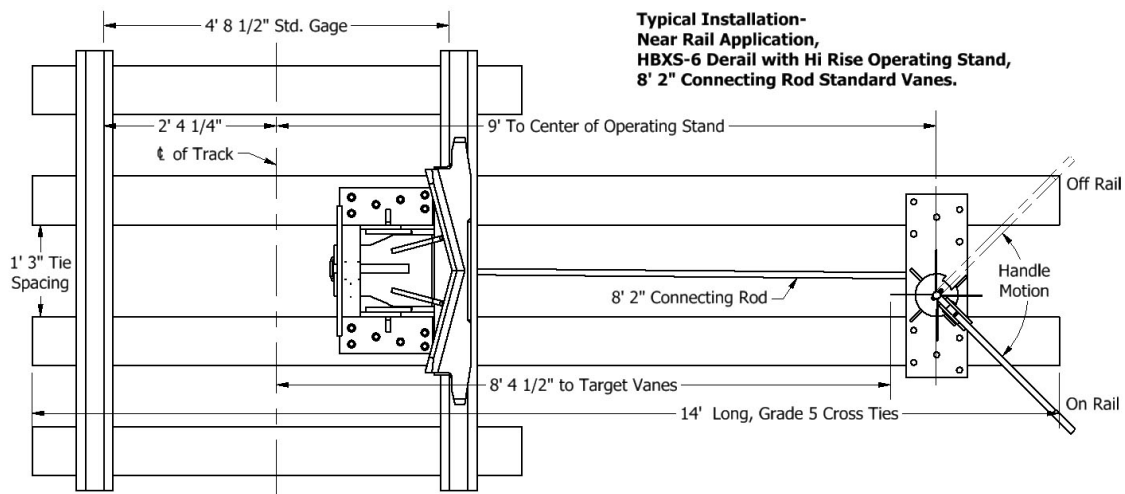
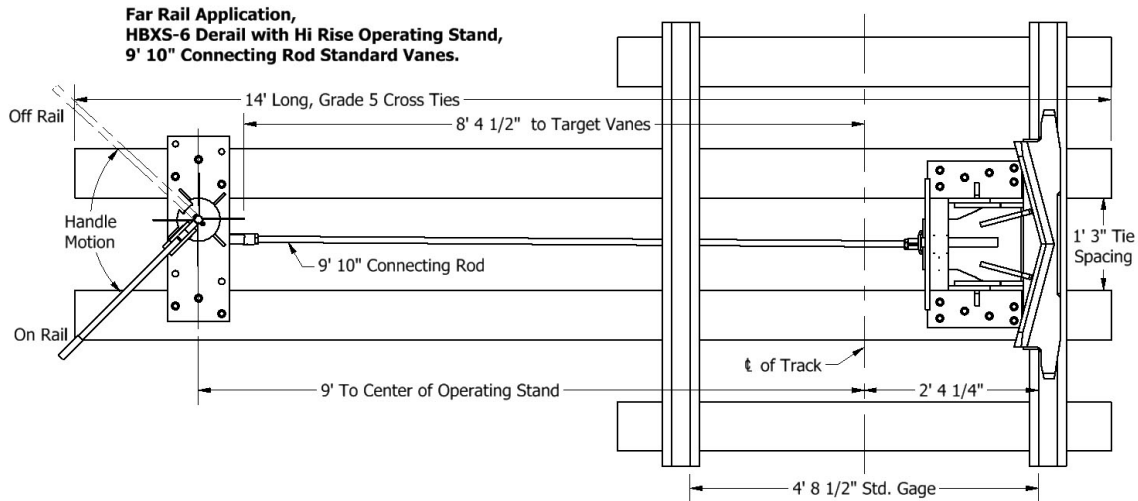

7.) Now, check the operation of the derail and operating stand combination, simply rotate the operating stand handle and observe the motion of the derail. If the derail and stand are installed correctly, the derail block will lift up and drop neatly back into the derail guide box, and the handle will fall into the lockable position on the stand. If the derail does not sit completely down on top of the box side plates the eyebolt will need to be adjusted. If the operating stand handle locks before the derail is down completely, unfasten the connecting rod and lengthen the eyebolt by turning it counterclockwise. If the derail sets down completely before the operating handle reaches the lockable position, shorten the eyebolt by turning it clockwise. Now, adjust the connecting rod and reinstall. Operate the derail to the "on rail" position, it should rise about 1 inch above the head of the rail and then fall firmly on top of the rail with no clearance between the underside of the derail block and the top of the rail. This allows the weight of the wheel to be transferred through the derail block directly to the rail, ties and ballast.

After confirming the correct installation and operation of the derail install lag bolts in remaining holes provided, make sure all rod connections are secure. The derail is now ready for service.

# Nomenclature - HB Derail

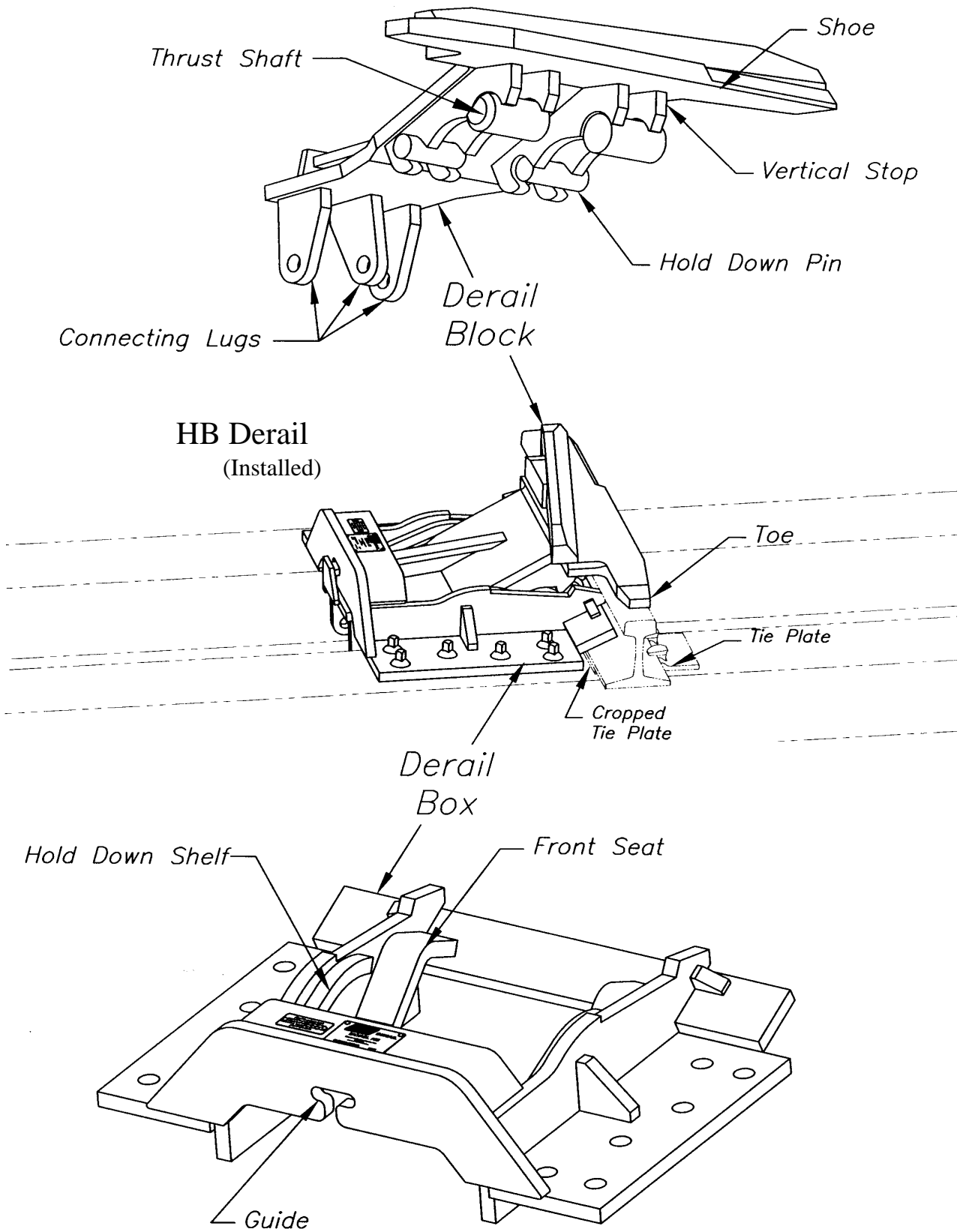

# HB Derail Dimension Diagram

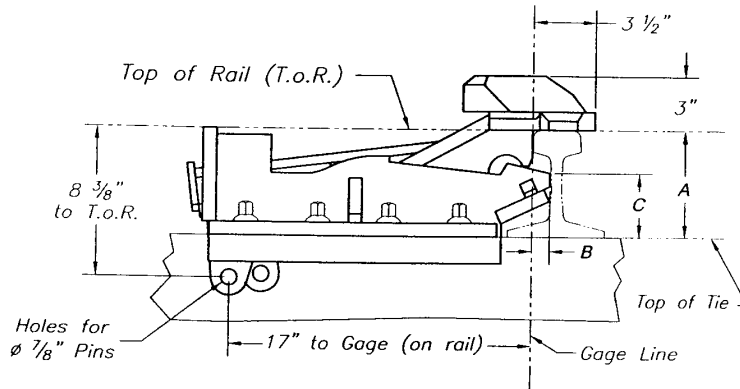

**Model HB side view on rail**

Dimension Table				
DERAIL SIZE	A	B	C	D
5	5"	1-1/8"	2-9/16"	6-3/8"
6	6"	31/32"	3-9/16"	7-3/8"
7	7"	1-1/8"	4-9/16"	8-3/8"
8	8"	1-1/8"	5-9/16"	9-3/8"

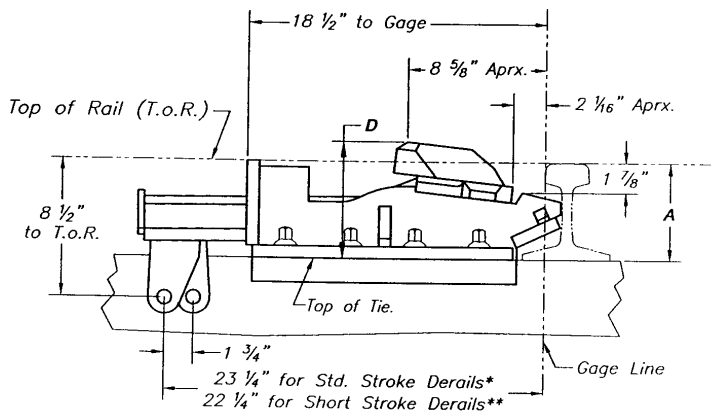

**Model HB closed (off rail) showing sample flangeway clearance.**

Std. HB Right Hand Derail Size 6 (HB6R) Shown.  
 Left hand Derail is Opposite (HB6L not shown).  
 Drawing is Not To Scale.

Two-way, Bi-directional Derails are also available:

Model HBXS Derails when installed properly derail both entering and exiting equipment.  
 All Model HB Derails may be ordered as Standard or Short Stroke.\*

\* Std. Stroke Derails have 6-1/4" Stroke.

\*\* Short Stroke (S.S.) Derails have 5-1/4" Stroke.

# Operating Stand Installation Instructions

Western-Cullen-Hayes manufactures several types of Operating Stands for our sliding derails. These instructions deal with our two most popular stands, the Two Tie Stand and the High Rise Operating Stand (HRS-100).

1. After the derail has been properly installed, place the Operating Stand on the head block ties on the same side of the track as the derail. The distance from the centerline of the track to the centerline of the target staff on the Two Tie stand should be 5 feet 10 1/4 inches, for the High Rise Stand that distance should be 9 feet.
2. Pin the connecting rod to the eye bolt of the Stand and to the center lug of the derail. When facing the derail the operating lever should be in the left notch of the Stand and the derail in the "on rail" position. Now, fasten the Operating Stand to the ties using lag screws in all the available holes in the horizontal flanges on the Operating Stand.
3. To adjust the stroke of the Operating Stand, turn the eye bolt in or out as necessary. The connecting rod length is adjusted by means of the screw jaws on each end of the rod. Keep in mind that eye bolt length changes the stroke of the derail. Rod length does not affect the derail stroke.
4. Operate the derail on and off the rail to make sure it seats properly and there is no binding of the connecting rod.
5. Attach the targets and optional lamp tip, if required.



# Wheel Crowder Installation Instructions

Western-Cullen-Hayes manufactures Models WC and WCX Wheel Crowders that may be installed with Model HB and HBXS derails respectively. The style of Wheel Crowder is always determined by the style of derail being used. The HB and HBXS derails also come in two different stroke versions: the standard stroke (6 1/4") version and the short stroke (5 1/4") version. Crowders and derails must be of the same size, stroke and hand to be effective.

Make sure that the installation site has good, sound ties, preferably new Grade 5. The ties must be perpendicular to the rails, and spaced properly so the connecting rod between the Crowder and derail does not rub or bind against the ties.

Once the derail, has been installed and is operating properly, the Crowder installation takes only a few minutes. Check the height of the rail and tie plate, if used, to make sure the height matches the size of the derail and Crowder. Six inches for a size six derail and Crowder, seven inches for a size seven, etc. It may be necessary to either shim the derail and Crowder up or adze the ties down to achieve the proper dimensions. Remember, if the derail is shimmed, the Crowder will need to be shimmed as well. Also, if there are tie plates involved, they will have to be cropped off even with the base of the rail on the gage side of the track. This is true for both the derail and Crowder.

After all the adzing, shimming and tie plate cropping has been performed, place the Crowder against the gage side of the rail opposite the derail. It should set flat on the ties and be in contact with the rail. Using the Crowder as a template, mark the location of the bolt hole at each end of the Crowder. Remove the Crowder and drill two holes through the rail for 1" diameter bolts.

Replace the Crowder. Install the two bolts but leave them loose. Use the two set screws on the Crowder to adjust the Crowder point to rail contact, if needed. There should be no gap between the Crowder point and the rail head. Snug the two 1" bolts, taking care not to lift the Crowder base plate. Now, secure the Crowder base plate to the ties with spikes or lag screws. Tighten the 1" diameter bolts.

Connect the offset connecting rod to the left hand derail lug. To determine which is the left lug, stand between the rails, facing the derail the lug on the left will be the "left hand" lug. We don't want to get confused on this point. Connect the other end of the rod to the oblong hole on the Crowder lever arm. Note: insulated offset rods are available at additional cost.

Operate the derail. On-rail the Crowder point should touch the rail head, and the springs should be slightly compressed. Off-rail, the Crowder point should be at least 2 3/4 inches away from the rail head for both the WC and WCX Crowders. Use the screw jaws on the offset connecting rod to adjust this dimension.